

EVA DL Lemi | LED Downlight



EVA Optic is specialist developer of high quality LED solutions for demanding environments. All products are developed and manufactured inhouse in the Netherlands.



>> EVA DL Lemi

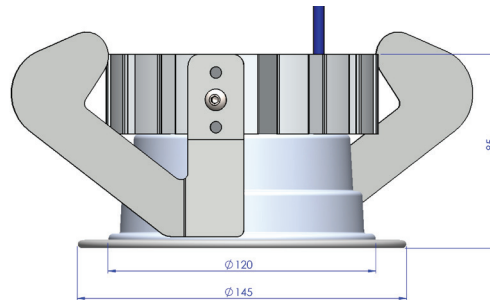

>> Dimensions light unit

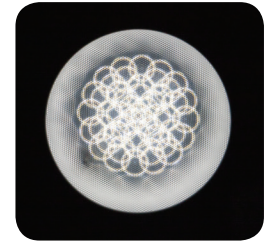

>> Front view:
illuminating surface
of downlight
Anti-glare (UGR <19)

EVA DL LEMI Mono

Type luminaire	IP50 LED downlight
Application	Sunken small downlight for industry and sports, not suitable for swimming pool areas
Material	Clear anodised coated aluminium (RAL 9010) with PMMA or PC (Sports) UGR <19 microprism cover
Max. energy consumption	8W - 11W - 14W - 17W - 21W - 25W (adjustable)
Powerfactor	> 0.9
Type LEDs	High-power multi chip LEDs
Lumen efficacy system 5000K	130 Lm/W (5000K)
Colour temperatures	2700K Extra warm white 3000K Warm white 4000K Neutral white 5000K Daylight white
Light beam angle	80°
Max. working temperature	45°C
Dimensions	∅ 125 mm, depth 85 mm
Outside diameter ring	∅ 145 mm
Cable length luminaire	0,5m GST 18/3
Driver input/output	100-240 Vac / 24Vdc
Driving technology	0-10Vdc
Max. cable length	100m (5x4mm ²)
Working temp. powerbox	-20°C to +40°C
Protections	Short circuit, overload, overvoltage, SELV equivalent, Class 2 output, double insulated
Options	ATS (Auto Temperature System), emergency units, DALI
Lifetime	50,000 hours L80/B20
Warranty	4 years

* Important! Always keep enough space (min. 5 cm) around the luminaire (including front), heatsink and powerbox for sufficient cooling.

EVA Optic is specialist developer of LED lighting for demanding environments. We have a complete range of LED lighting for public pools and indoor sports facilities. We also have a range of high-quality lights for industry and utility. All our lights are developed and manufactured in-house in the Netherlands. The advantages of EVA LED lighting:



OPTION: Auto Temperature System (ATS) - smart protection against LED overheating

For optimal lifetime of the LEDs it is very important to prevent the LEDs from overheating. EVA Optic LED lights with ATS regulates its own temperature. When the temperature of the LEDs is too high, the lighting system automatically dims back slightly until the desired balance between the ambient temperature and the LED temperature has been restored. The difference is so minimal that you do not perceive it, but the lighting will last for many years longer because of it.



Athlete-friendly lighting

LED is spot lighting and can therefore be extremely bright, creating blinding glare. EVA Optic swimming pool and sports lighting have very low glare rate (UGR < 19) because of the unique microprism cover. The cover ensures that powerful lights create minimal glare and are extremely suitable for sports environments. The low glare rate ensures powerful yet pleasant light with optimal visibility, even when glancing directly into the light.



No loss of LED capacity in multi-coloured lights (RGBW lights)

EVA Optic developed Intelligent Power Control (IPC) for multi-coloured RGBW lights. With IPC the LED's full capacity is used at all times. Due to the constant light output, a pool is optimally illuminated regardless of the light colour. Without IPC part of the RGBW light's capacity is lost. Depending on colour choice, this loss can reach up to 75%.



Fast Return on Investment

Smart design, use of the newest developments in LED technology and unique driving functionalities make EVA Optic swimming pool & sports lights very efficient. When replacing traditional lighting solutions (TL, metal halid, PL) with comparable light output, the average payback time is 2-5 years.